

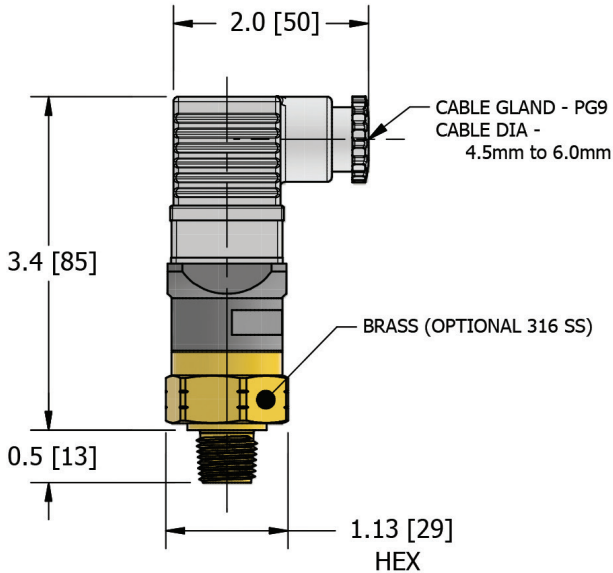

FEATURES / BENEFITS

- Rugged brass construction
- Vacuum pressure range from 5–30” Hg (0.17–1.02 bar)
- Withstands positive pressure up to 350 psi / 24.1 bar
- 5 Amp SPDT snap action microswitch
- IP 65 Environmental protection

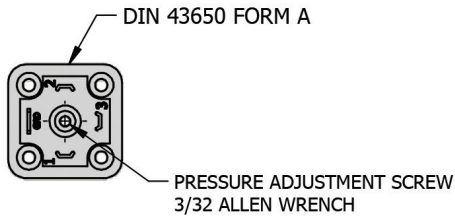

SPECIFICATIONS

MECHANICAL

Set Point Ranges	5–30” Hg (0.17–1.02 bar)
Repeatability	+/- 2% FS
Maximum Overpressure	350 psi (24.1 bar)
Mechanical Life	1,000,000 Cycles
Temperature Range	-20–180° F (-29–82°C)

PHYSICAL

Housing Material	Brass, Optional: Stainless Steel—may extend delivery time
Diaphragm	Nitrile (other options available on request)
Pressure Port	1/4” NPT Male
Environmental Protection	IP 65
Electrical Connection	Din 43650 A
Weight	0.26 lbs (0.12 kg)

ELECTRICAL

Switch Type	SPDT Snap Action
Current Rating	5 A 12/24 VDC - 125 VAC 3 A 250 VAC Optional: 10 A or Gold Contacts—may extend delivery time



Model Number	Part Number	Adjustment Range	Average Differential
220V-0-4M-C-HC	D32000	5–30” Hg (0.17–1.02 bar)	2–4” Hg (0.07–0.135 bar)

220V SERIES